

GENERAL SPECIFICATIONS

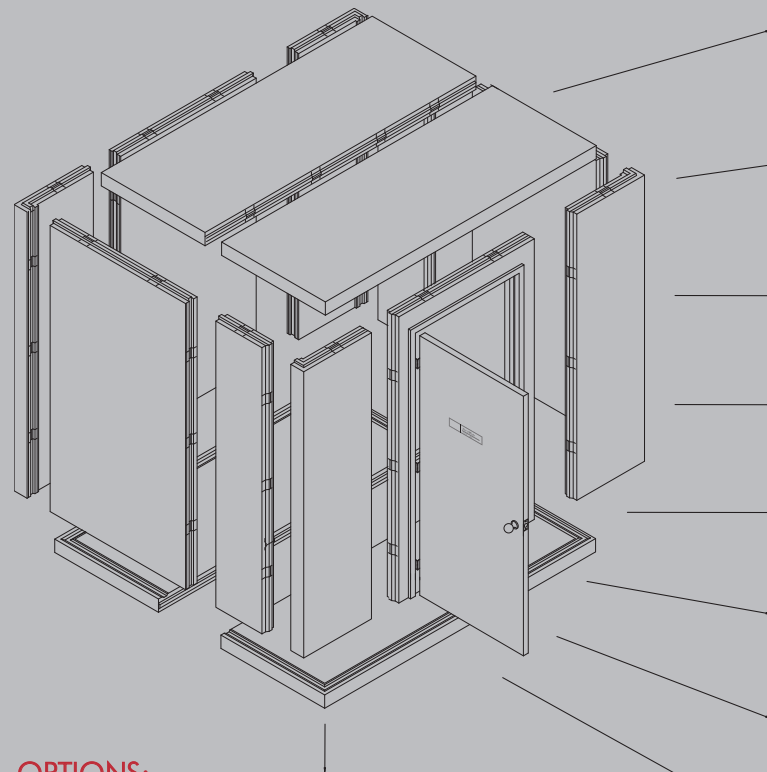

OPTIONS:
HVAC systems, electrical packages, entry ports, equipment racks and lighting provisions upon customer request. All options can be factory installed or supplied for field install.

WARRANTY:
Limited 10 year panels.

CONSTRUCTION:
Modular Panels are connected with cam lock connectors. All walls, ceilings, and floor panels use no wood unless otherwise noted.

FINISH:
26 gauge galvanized steel with a baked on enamel finish in white or tan color. Other options available.

JOINTS:
All joints are sealed with a factory installed, rubberized gasket system.

DOORS:
Pre-installed high quality commercial doors. Available in various dimensions.

FLOORS:
Available in floor and no-floor configurations. Standard floor load up to 600 psf.

ELECTRICAL:
Built to customer specification. All conduit surface mounted.

ROOF COVERING:
Thermo-plastic membrane included. Sloped and other roofing systems available.

FLAME AND SMOKE RATING:
All panels insulated with R-18 Expanded Styrene or R-32 Extruded Styrene meeting U.L. 25 Flame Spread Rating with avg. smoke rating less than 165.



versatile by design >



325 Payson Avenue, Quincy, Illinois 62301
800.728.5454 Fax 217.228.2424
www.envirobuildings.com

A DIVISION OF



For over 20 years, Enviro Buildings has been manufacturing customized Industrial Buildings for a variety of applications in two convenient configurations—Panelized and Pre-Assembled Buildings.

PANELIZED BUILDINGS

Panelized Buildings arrive in a knock-down configuration along with detailed instructions and drawings. The included cam wrench is the only tool needed for assembly—no bolts, no screws, no drills. Most panelized buildings can be field-assembled in a matter of hours.



PRE-ASSEMBLED BUILDINGS

Enviro Buildings specializes in manufacturing turnkey pre-assembled Industrial Buildings at a reasonable price. The enclosures are delivered on a forkliftable skid which allows easy mobility upon delivery (and for future relocations.)

Pre-assembled buildings are not only created for indoor applications, but outdoor as well. Outdoor buildings are completely weather and pest proof. The weather membrane installed on the roof is guaranteed to prevent any leaking and the insulation is a natural pest deterrent.



ADVANTAGES

- > **Superior Design**
Enviro Industrial Buildings are constructed with 4" expanded (R-18) or extruded (R-32) polystyrene which provides excellent insulation for each application.
- > **Simple and Quick**
Time, space and production are effected during traditional construction. Since Enviro Buildings can be delivered pre-assembled or field-assembled in a matter of hours, production is not interrupted and construction messes are avoided.
- > **Flexible**
The cam-locking panelized walls make moving, expanding and dividing buildings and walls easy. Customers need only to unlock the end panels, add new ceiling, floor and wall panels, and then reinstall the end panels to have an expanded building at minimal expense.



- > **One Tool**
The cam wrench is the ONLY tool needed to assemble an Enviro Building.



CONSTRUCTION

Enviro Buildings are constructed with 4" high density foam insulation to provide the best insulation and durability. Because of the insulation's high R-value, the Industrial Buildings can be designed to maintain temperatures from -20 degrees to 120 degrees Fahrenheit.

To prevent air infiltration, Industrial Buildings are fit together using a tongue and groove routing system and then locked side by side with cam locks. To protect the seal even further, gaskets are placed along all edges of the panels. When the cams lock tight, the gaskets provide an air tight seal which is optimal for temperature and dust infiltration control.

MEZZANINES • GUARD HOUSES • CLEAN ROOMS • FOOD SERVICE ROOMS • PAINT BOOTHS • UTILITY BUILDINGS • BUS STOP ENCLOSURES • EQUIPMENT ENCLOSURES • BREAK ROOMS

APPLICATIONS



PLANT OFFICES

In-plant offices are ideal for customers on a budget and/or time constraint. Enviro Buildings offers in-plant offices in a variety of colors and finishes with multiple accessories.



COMPUTER ROOMS

Enviro Buildings are unsurpassed in preventing dust infiltration into delicate equipment. As the need for computer equipment grows, so can the size of your computer room by simply unlocking the walls and adding more panels.



MANUFACTURING ENCLOSURES

The high density foam used in our manufacturing enclosures helps isolate equipment sounds while keeping items in a clean atmosphere.



LABORATORIES

Environmental control is critical in laboratories; Enviro Buildings offer the ideal defense against bacteria, dirt and dust particles along with a choice of wall finishes—stainless steel, aluminum and galvanized steel with white baked enamel finish.



WALL PARTITIONS

Prefabricated office walls not only install quickly—they reduce the mess and disruptions that accompany traditional construction.